

Economical, Automated Pipe Cutter Saves Layout and Fit-Up Time

MM1

Programmable Pipe Cutter

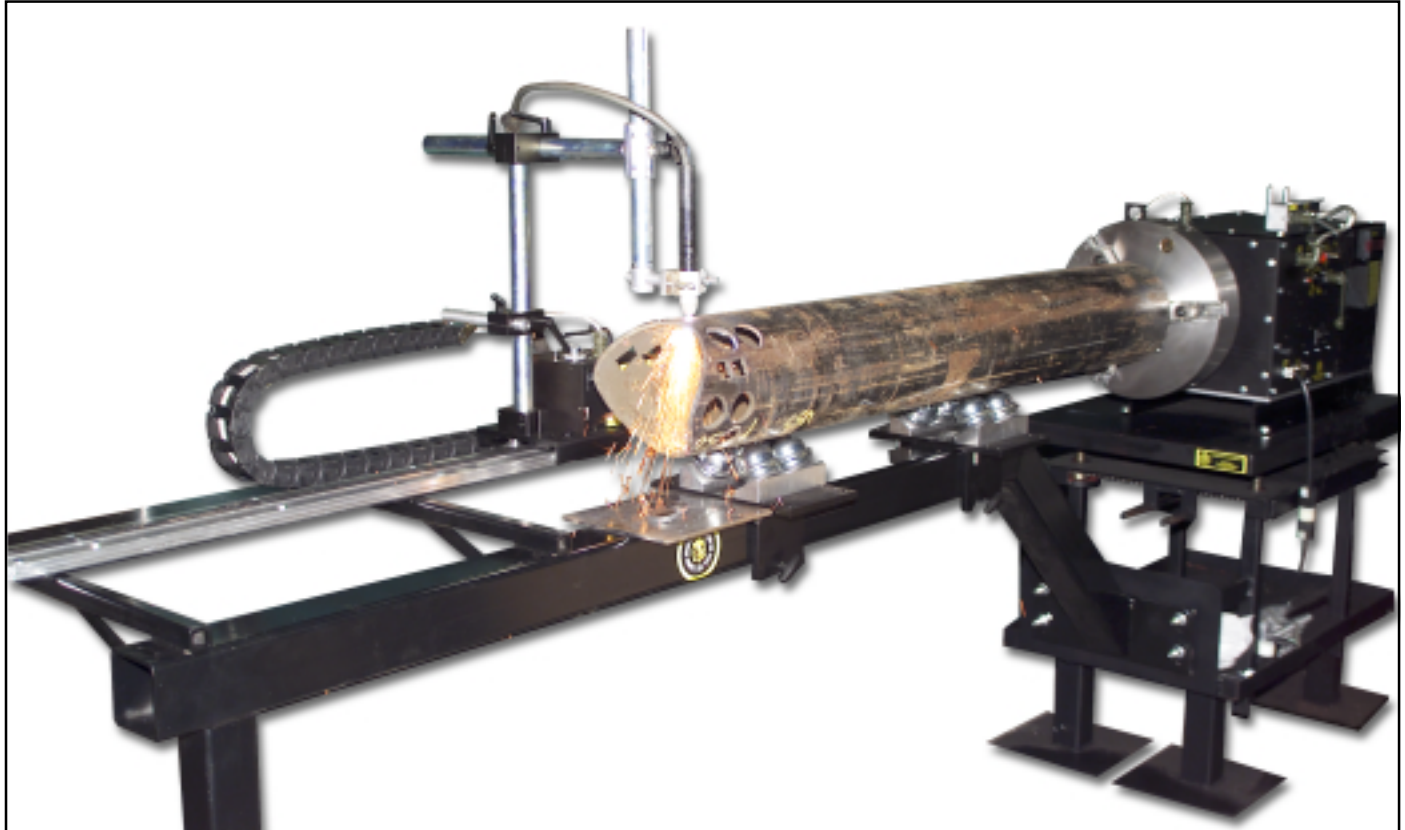

The MM1 is a computer-controlled machine that automates the cutting of profiles, holes, nozzles and shapes on pipe with diameters from 4" to 16" (10-40 cm). It rotates the pipe on its roller bed with a three jaw chuck while simultaneously moving a cutting torch back and forth along the pipe's axis. Pre-programmed shapes such as saddle, hillside, lateral and miter cuts can be made by simply selecting the type of cut from the menu, then entering the diameters of the pipe being processed and pressing the run button to cut your pipe. No need for templates. No time consuming layout or calculations to do. In addition irregular or uncommon shapes can be plotted, programmed and saved for future use.

The machine's pipe bed is designed for handling lengths of pipe up to 6' (1.83 m) long. Additional pipe bed extensions of 8' (2.44 m) can be added to make up to a 38' (11.6 m) bed. The method of cutting can be oxy-fuel or plasma. If oxy-fuel is used, the machine will be equipped with solenoids and a three-hose cutting torch. When plasma is used, a rotary ground is installed on the machine. The machine can be delivered with plasma torch leads and power source or the customer may provide his own plasma equipment.



CYPRESS WELDING EQUIPMENT INC.

CE

A DIVISION OF WELD TOOLING CORPORATION

3001 West Carson Street • Pittsburgh, PA USA 15204-1899
Telephone: 1-412-331-1776 • 1-800-245-3186 • Fax: 1-412-331-0383
<http://www.cypressweld.com>

MM1 Programmable Pipe Cutter - Technical Data

Technical Data:

Cutting Diameter: 4"-16" O.D. (10-40 cm)
Load Capacity: 1600 lb. (725 kg)
Dimensions: 137"L x 36"W x 55"H
 (348 cm L x 91 cm W x 140cm H)
Input Power: 115 VAC / 240 VAC
Net Weight: 550 lbs (250 kg)
Shipping Weight: 800 lbs. (363 kg)

Programming Custom Shapes.

Types of Cuts:

A. Pipe Program

1. Saddle Cuts
2. Offset from Center-Line (Hillside)
3. Lateral Cuts
4. Miter Cuts
5. Hole Cuts

B. Shape Program

1. Custom Irregular Shapes

PART NUMBER	DESCRIPTION
SEO-3500	MM1 120V
SEO-3502	MM1 240V

(See detail below.)

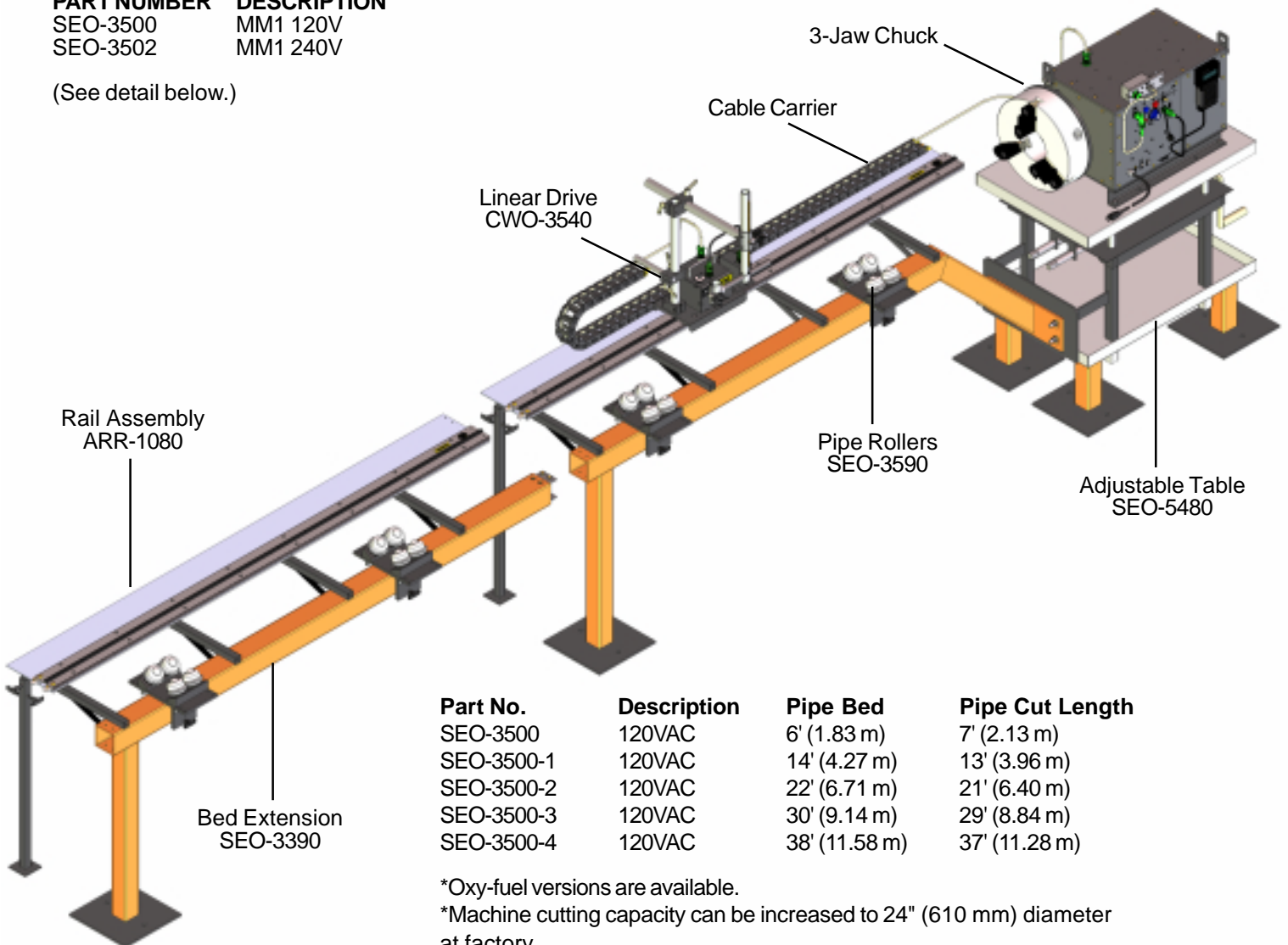

Part No.	Description	Pipe Bed	Pipe Cut Length
SEO-3500	120VAC	6' (1.83 m)	7' (2.13 m)
SEO-3500-1	120VAC	14' (4.27 m)	13' (3.96 m)
SEO-3500-2	120VAC	22' (6.71 m)	21' (6.40 m)
SEO-3500-3	120VAC	30' (9.14 m)	29' (8.84 m)
SEO-3500-4	120VAC	38' (11.58 m)	37' (11.28 m)

*Oxy-fuel versions are available.

*Machine cutting capacity can be increased to 24" (610 mm) diameter at factory.

When inquiring about 24" (610 mm) diameter models, the machine part number will be followed by -24.

MM1 Programmable Pipe Cutter - Programming

Main Control Panel

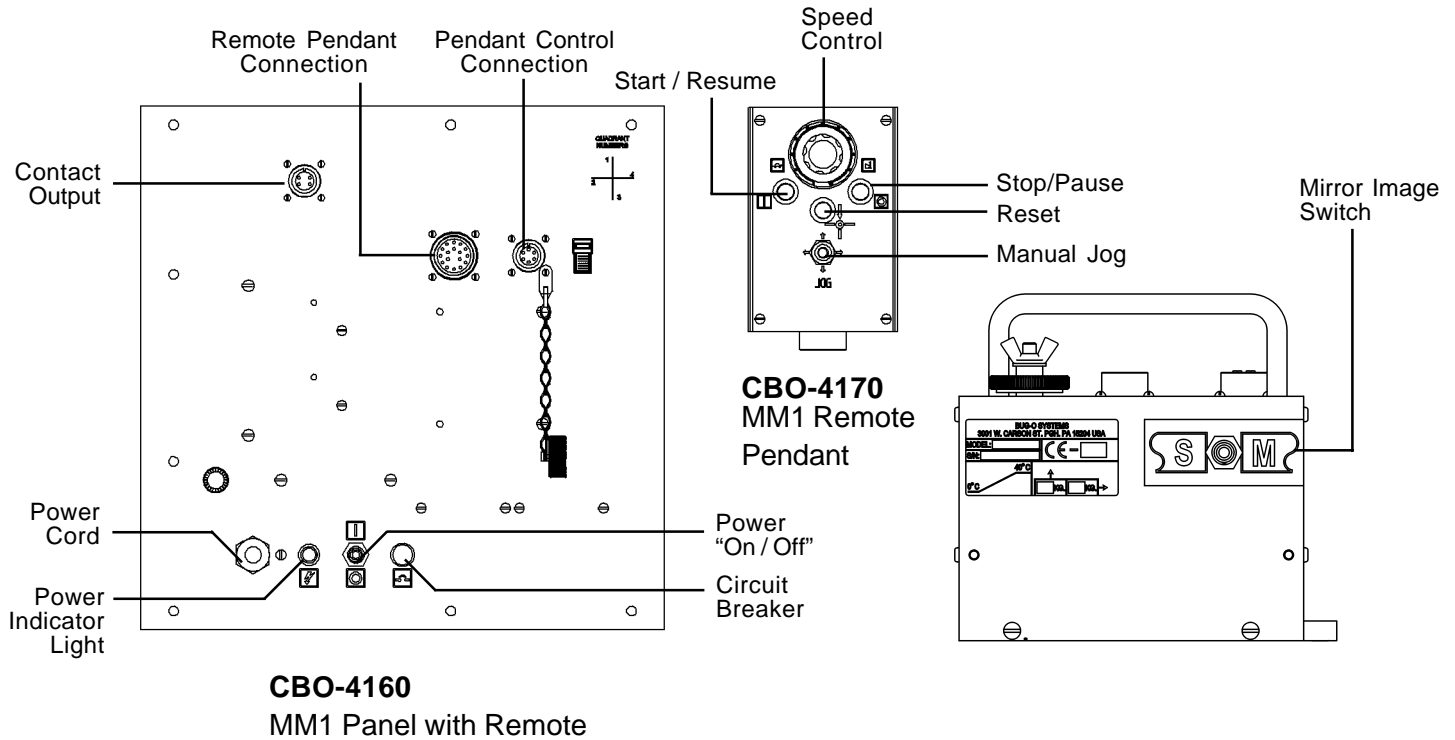

Programming With The Handheld Terminal

To cut a nozzle or hole, the sequence of actions would be to take the handheld terminal connected to the Control Panel and:

1. Press the reset button on the machine. The handheld terminal will display "READY".
2. Press "A" on the terminal. The terminal will ask you what type of cut you want. (See Types 1-5, Page 4).
3. Press the number desired and then press "ENTER".
4. The terminal will ask for the diameter of the small pipe. Press the appropriate dimensions and press "ENTER".
5. The terminal will ask for the diameter of the large pipe. Press the appropriate dimensions and press "ENTER".
6. Enter the offset dimension if cutting a hillside nozzle.
7. Enter the "ANGLE" in degrees if cutting a lateral.
8. Press "START" on the machine to begin to cut.

When using Plasma, press "B" and enter the time delay required (which is stored until changed again.)

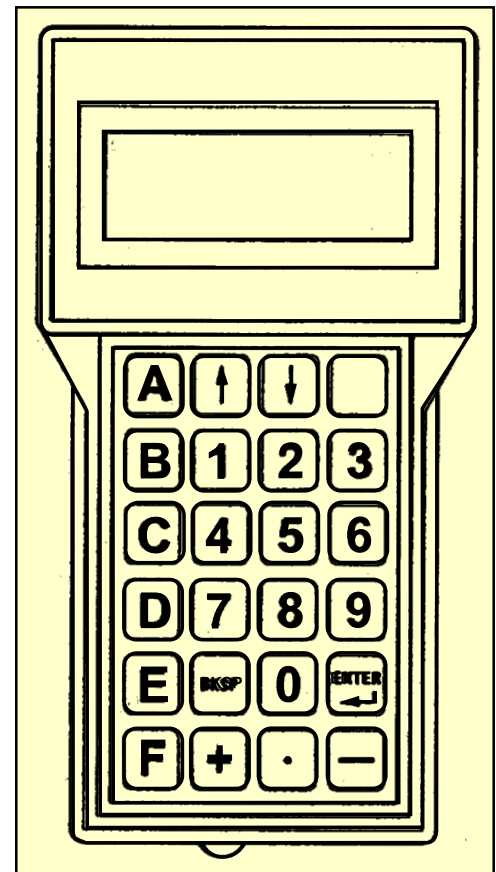

MM1 Programmable Pipe Cutter - Programming

Capabilities

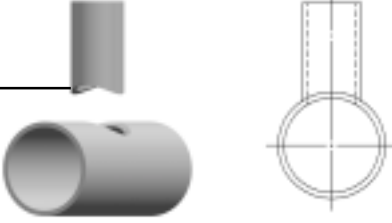
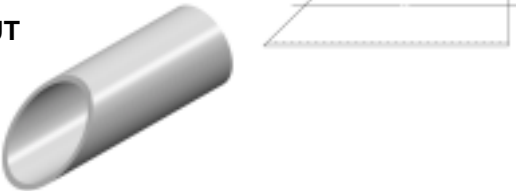
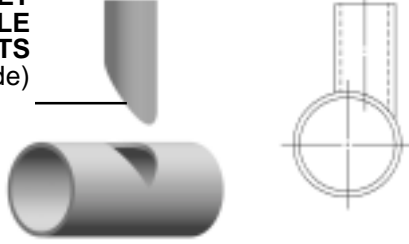
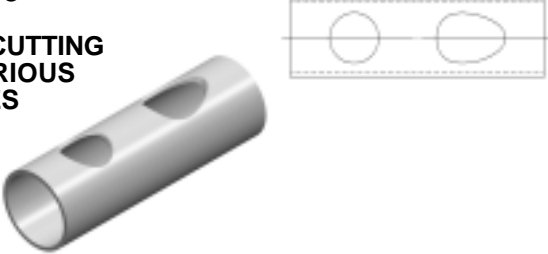
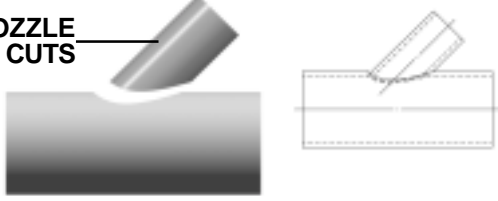
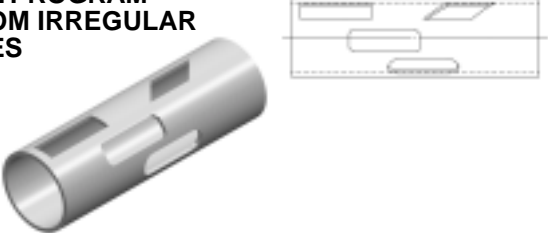
<p>TYPE 1</p> <p>SADDLE NOZZLE CUTS</p> 	<p>TYPE 4</p> <p>MITER CUT</p> 
<p>TYPE 2 OFFSET SADDLE NOZZLE CUTS (Hillside)</p> 	<p>TYPE 5</p> <p>HOLE CUTTING AT VARIOUS ANGLES</p> 
<p>TYPE 3</p> <p>LATERAL NOZZLE CUTS</p> 	<p>SHAPE PROGRAM</p> <p>CUSTOM IRREGULAR SHAPES</p> 

Segment Type and Line Chart									
Quadrant:	#4					TIME DELAY	PERCENT SPEED		
	#3					WAIT FOR START BUTTON	AUXILIARY MODES		
	#2					WELD/OXY OFF	PIPE CUT NUMBER		
	#1					WELD/OXY ON	REPEAT ANOTHER STEP		
		1. Clockwise 90 Deg Arc	2. Counter-Clockwise 90 Deg Arc	3. X or Y Axis Line	4. Oblique Line	5. Functions	6. Functions	7. Clockwise Partial Arc	8. Counter-Clockwise Partial Arc
Segment Types:									
A. All Segments - Build New Shape			B. Reprogram One Segment			C. Change Shape Number			
D. Display Current Shape Data			E. End of Segment Slowdown						

Programming Arbitrary Shapes

For custom shapes select the "shape" software. Programming is simple but will require a few more steps due to all the variations possible.

First, the developed pattern should be laid out as if the pipe is unrolled flat. The cut is then split into a sequence of straight lines or circular arcs that make up the desired pattern.

Next, these should be listed in a table on paper, with the type, quadrant and required dimensions (referring to the chart in the Instruction Manual).

To program the shape, press "A", then enter the total segments at the prompt.

Next, the data for each segment – type, quadrant and dimensions – are entered in turn, at the prompt.

MM1 Programmable Pipe Cutter - Accessories



BUG-1274
3-Hose Machine Torch 10"
(254 mm) Cutting Torch is
the same for Acetylene-
Propane-Natural Gas. Only
the tip changes.

CWO-7635 Powermax 1250

Includes the following:

- Interface cable to the Cypress Pipe Cutter
- 50' (15.24 m) Machine Barrel Torch

Power Requirements:

Auto voltage runs on 200-
600 Volts, 1 or 3-phase,
without the need of
rewiring.

Adjustable Output

Current: 25-80 Amps

Cutting Capacity:

(Recommended) 7/8"
(22 mm)

CWO-7636

Consumable Kit for
CWO-7635



Oxy-Acetylene Tips					
PartNo.	Tip Size	Plate Thickness	Oxygen PSIG	Fuel Gas PSIG	Orifice Drill Size
BUG-1270-000	000	Light Gauge to 3/16	15-20	5-15	#68
BUG-1270-00	00	3/16-3/8	20-25	5-15	#64
BUG-1270-0	0	3/8-5/8	35-40	5-15	#60
BUG-1270-1	1	5/8-1	35-40	5-15	#56
BUG-1270-2	2	1-2	40-45	5-15	#52
BUG-1270-3	3	2-3	45-50	5-15	#48
BUG-1270-4	4	3-6	50-75	10-15	#42

* For tips to cut 6" to 15", please consult factory.

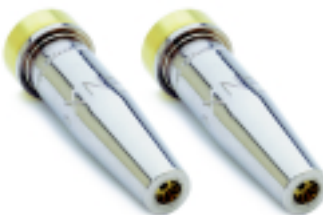

Oxy-Propane, Natural Gas Cutting Tips					
PartNo.	Tip Size	Plate Thickness	Oxygen PSIG	Fuel Gas PSIG	Orifice Drill Size
BUG-4070-000	000	Light Gauge to 3/16	15-30	5-15	#68
BUG-4070-00	00	3/16-3/8	20-30	5-15	#64
BUG-4070-0	0	3/8-5/8	30-40	5-15	#60
BUG-4070-1	1	5/8-1	35-50	5-15	#56
BUG-4070-2	2	1-2	40-55	5-15	#52
BUG-4070-3	3	2-3	45-60	5-15	#42
BUG-4070-4	4	3-6	50-75	5-15	#42
BUG-4070-5	5	6-8	65-80	5-15	#35
BUG-4070-6	6	8-12	70-90	5-15	#30

MM1 Programmable Pipe Cutter - Dimensions

Dimensions:

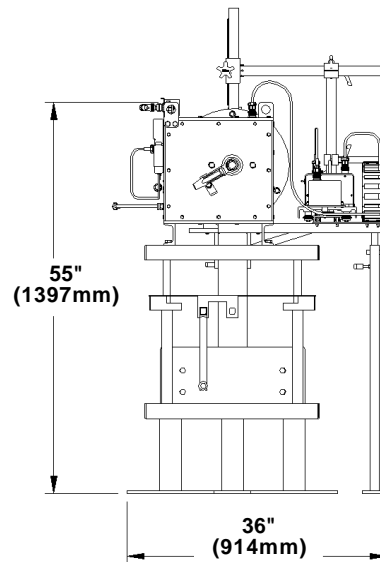
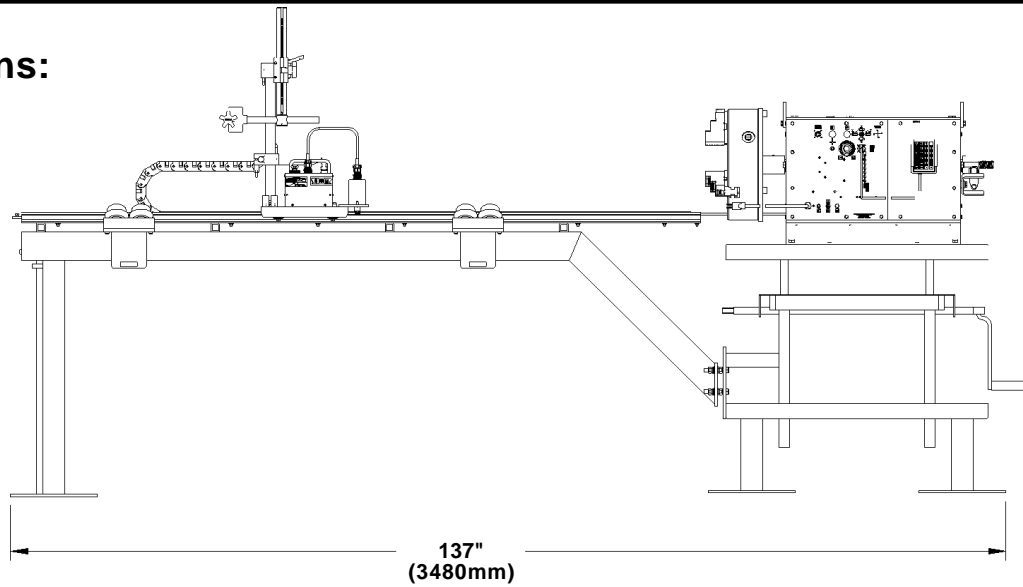

CYPRESS WELDING EQUIPMENT, INC.

A DIVISION OF WELD TOOLING CORPORATION

3001 West Carson Street • Pittsburgh, PA USA15204-1899
Telephone: 1-412-331-1776 • 1-800-245-3186 • Fax: 1-412-331-0383

<http://www.cypressweld.com>

LIT-BRO-MM1-0507